



Dewhurst US90-15 Compact 3/3P Pushbutton

The US90-15 Braille Pushbutton meets all the requirements of the visually impaired. As well as the 15mm high tactile legend, Standard English Braille dots are embossed onto the pushbutton. The illuminated tactile legend provides clear identification and the button can be illuminated in a wide variety of colours. The US90-15 is available with the standard Compact 3 body or Compact 3P, a useful option for surface mount fixtures.

Features & Benefits

- 15mm tactile legend with Braille
- A halo of light between the pressel and surround via a patented hidden recess encircles the pressel and illuminates the legend
- Legend & halo can be constantly illuminated at half intensity, switching to full intensity for indication of position or call acceptance
- Large range of pressel legends
- Matching range includes keyswitches, rocker switches and indicators
- Also available with C2 body
- Vandal resistant with stainless steel front
- Meets EN81-1/2, EN81-71 (Category 2), EN81-72, EN81-73, EN60529 (IP54), AS1735 Part12 with H/C surround & dual illumination



Illumination, Finishes & Marking

* Standard pressels are a brushed stainless steel plate moulded with red or grey polycarbonate

- Wide range of colours for illumination including (non), red, yellow, green, blue and white
- Range of pressel finishes including brushed stainless steel, mirror stainless steel, brushed brass and mirror brass*
- Range of surround finishes and heights - chrome, brass, black - 3.2 and 4.8mm
- Single, dual and bicolour illumination
- A large range of legends in Helvetica Medium characters & symbols are available
- 15mm high, tactile, red or grey characters/symbols are formed during the moulding of the pressel. Standard English Braille appears below the characters/symbols.



Dimensions

C3		C3P	
SINGLE	DUAL/BI/BI+	SINGLE	DUAL/BI/BI+
1 = FULL (+) 2 = FULL (-)	1 = FULL (+) 2 = FULL (-) 3 = DIM/BACKGROUND (+)	1 = FULL (+) 2 = FULL (-)	1 = FULL (-) 2 = FULL (+) 3 = DIM/BACKGROUND (+)
Please note the orientation of PCB notches to the tab (C3) or cable (C3P) numbers		1 = RED 2 = BROWN OR	1 = BROWN OR BLACK 2 = RED 3 = ORANGE OR RED 4 = YELLOW OR BLACK

Compact 3/3P Pushbuttons can be supplied loose or incorporated into stations with 1.5mm or 2.5mm stainless steel faceplates, with a vertical pitch of 50mm and horizontal pitch of 60mm (C3) or 80mm (C3P) i.e the pushbutton body can be rotated through 90 degrees (horizontal version shown above). If pushbuttons are supplied loose, spacers are provided to accommodate the differing faceplate thickness.



Technical Details

Weight:	70grms
Moulded in:	High grade polycarbonate
Pressel plate material:	Brushed 304 stainless steel (standard)
Pressel plate area:	620mm ²
Button force:	3.5N
Pushbutton size:	C3 = 59.1mm w x 44.6mm h x 25.5mm d C3P = 59.1 mm w x 44.6mm h x 18mm d
Pressel size:	24.2mm w x 24.2mm h x 3.2mm d
Legend size:	15mm high, Helvetica medium characters
LED current:	20mA (typically)
LED voltage:	6/12/24/110V a.c./d.c. ±15% (6V only available in red and yellow)
Operation:	Wiping action, slow make and break with solid silver contacts
Ratings:	10 amps max
	240V a.c. at 3.0 amps max. resistive loads - min. no. of operations: 1 x 10 ⁶
	240V d.c. at 0.5 amps max. resistive loads - min. no. of operations: 2 x 10 ⁶
	110V d.c. at 100mA max. inductive TC40ms - min. no. of operations: 1 x 10 ⁶
	12V d.c. at 5mA max. resistive loads - min. no. of operations: 10 x 10 ⁶
Contact arrangements:	2 N/O, 2 N/C or 1 N/O + 1 N/C <small>Please note that it is possible for the N/O contact to make before the N/C contact has opened on the 1 N/O + 1 N/C configuration</small>
Code compliance:	Meets EN81-1/2, EN81-71(Category 2), EN81-72, EN81-73
IP Rating:	EN60529 (IP54)

Cutouts & Stud Positions

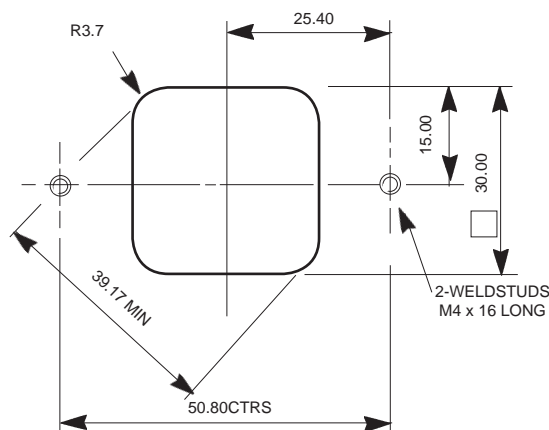

Cleaning your US90-15 Pushbutton

Many Dewhurst lift products are made of polycarbonate (Using GE's Lexan® or Bayer's Makrolon®).

The US90-15 is highly durable and vandal resistant but the plastic parts can be damaged by aggressive cleaning agents, Dewhurst therefore recommends:



Clean the part with a cotton cloth and warm water before applying the cleaning product



Use PH-neutral or slightly acid cleaning products only (including aromatised ones) Ethylic alcohol, isopropyl alcohol or ethylene glycol based multipurpose cleaning products and dish soaps are suggested.



Dilute the cleaning product in warm water and apply using a wet cotton cloth.



Grease, glue and paint may be removed with ethylic alcohol or isopropyl alcohol.

Recommended Cleaning Products (*):

Europe	North America
Windus - Brial Top - Ecolab Mr. Proper Surfaces Delicates - Proctor & Gamble Palmolive, Colgate Palmolive	Formula 409® Cleaner Degreaser Joy®, Proctor & Gamble Windex, Drackett Products Palmolive, Colgate Palmolive

(* Due to the vast number of cleaning products available on the market, the list of recommended products above is an illustration only

Note:

- Do not use abrasive cleaning agents
- Do not use sharp tools to remove dirt (chewing gum, glue, etc.)
- Do not use solvents based with Ketones, benzene, methanol, toluene (also known as methylbenzene or phenyl methane) or alkaline and ammonia based cleaning agents
- Do not use cleaning agents at high temperatures
- Do not leave cleaning agents on the parts for long periods: remove immediately after cleaning using a wet cotton cloth and warm water
- Do not use dry cotton cloths and sponges

pushbuttons

US91-15



US91-15

The US91-15 Braille pushbutton meets all the requirements of the visually impaired. As well as the 15mm high tactile legend, Standard English Braille dots are embossed onto the pushbutton. The illuminated legend provides clear identification and the button can be illuminated in a wide variety of colours. The US91-15 is available with the standard Compact 2 body, or Compact 2 Micro, a useful option for surface mount fixtures.

key features

- 15mm tactile legend with Braille
- Legend and halo illumination
- Vandal resistant with stainless steel front
- Large range of pressel legends
- Standard pressels are a stainless steel plate moulded with red or opal polycarbonate

Dewhurst plc
Inverness Road
Hounslow
Middlesex TW3 3LT UK

Tel: +44(0) 20 8607 7300
Fax: +44(0) 20 8572 5986
Email: info@dewhurst.co.uk
www.dewhurst.co.uk

specification

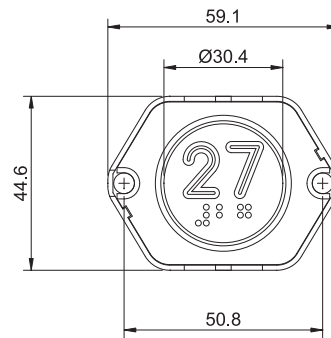

This product is designed to meet the requirements of the following codes and regulations either in its standard form or through variants.

EN81-1/2	✓
BS8300	X
M2/S2	X
EN81-70	X
B44	X
EN81-71	*
AS1735.12	✓
EN81-72	✓
A117.1	X
EN81-73	✓
EN60529	IP54

* Compact 2 = Category 2
Compact 2 Micro = Category 1

For more information on our pressel range contact us at:

Dewhurst plc
Inverness Road
Hounslow
Middlesex TW3 3LT UK

Tel: +44(0) 20 8607 7300
Fax: +44(0) 20 8572 5986
Email: info@dewhurst.co.uk

www.dewhurst.co.uk

technicals

- Moulded in high grade polycarbonate
- LED current 20mA
- A detailed data sheet for this product can be found on our website

benefits

- Matching range includes keyswitches, rocker switches and indicators
- Matching range of Jumbo buttons
- Vandal resistant

options

- Wide range of colours for illumination including red, white, green, yellow and blue
- Single, dual and bi-colour illumination
- Available with either C2 or C2 Micro body
- Range of pressel finishes available stainless steel, brass, mirror and others
- Elongated version available for extra thick faceplates such as glass