

indicators

UniBlade Lantern

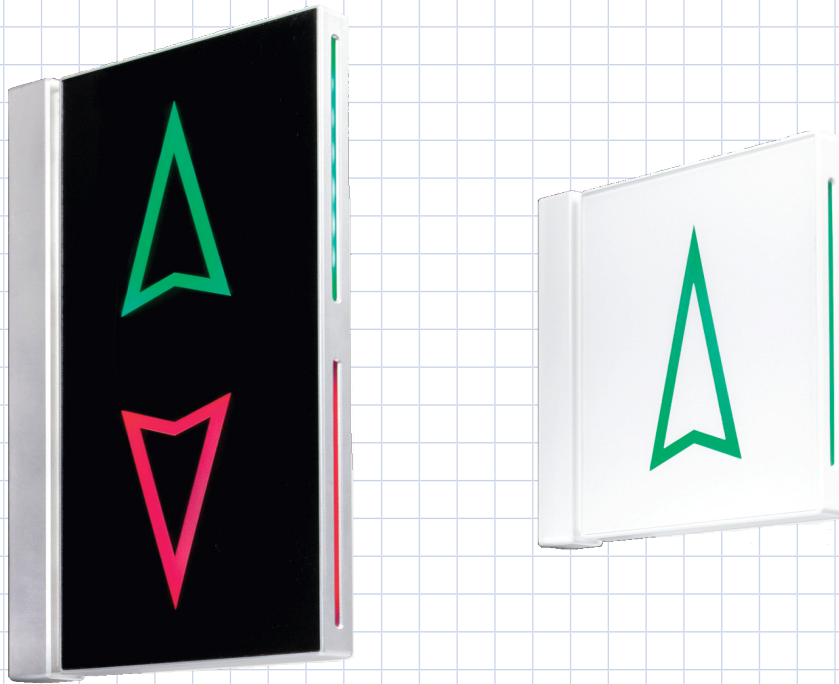

UniBlade Lantern

The UniBlade is our new design for hall lanterns. The design is clean and modern, with a range of colour options for the body such as natural, black and white.

The UniBlade lantern is ideal for use in a lift lobby where there are three or more cars and it is not always easy to see which lift has arrived. The UniBlade stands out at right angles to the wall and when illuminated, clearly identifies the lift that has arrived.

The side panels of the UniBlade Hall Lantern are available in black or white, with a range of illumination colours.

The unit's design looks 'custom' but this is a standard production unit that offers excellent value for money.

Key features

- Smart, modern appearance
- Side panel colour available in black or white, others colours on request
- Easy installation, with or without faceplate
- Meets DDA requirements
- Wide range of colour options
- Gong optional

Dewhurst UK Manufacturing Ltd
Unit 9, Hampton Business Park
Feltham
TW13 6DB
United Kingdom

Tel: +44(0) 20 8744 8200
Fax: +44(0) 20 8744 8299
Email: info@dewhurst.co.uk

www.dewhurst.co.uk

specification

UniBlade Lantern

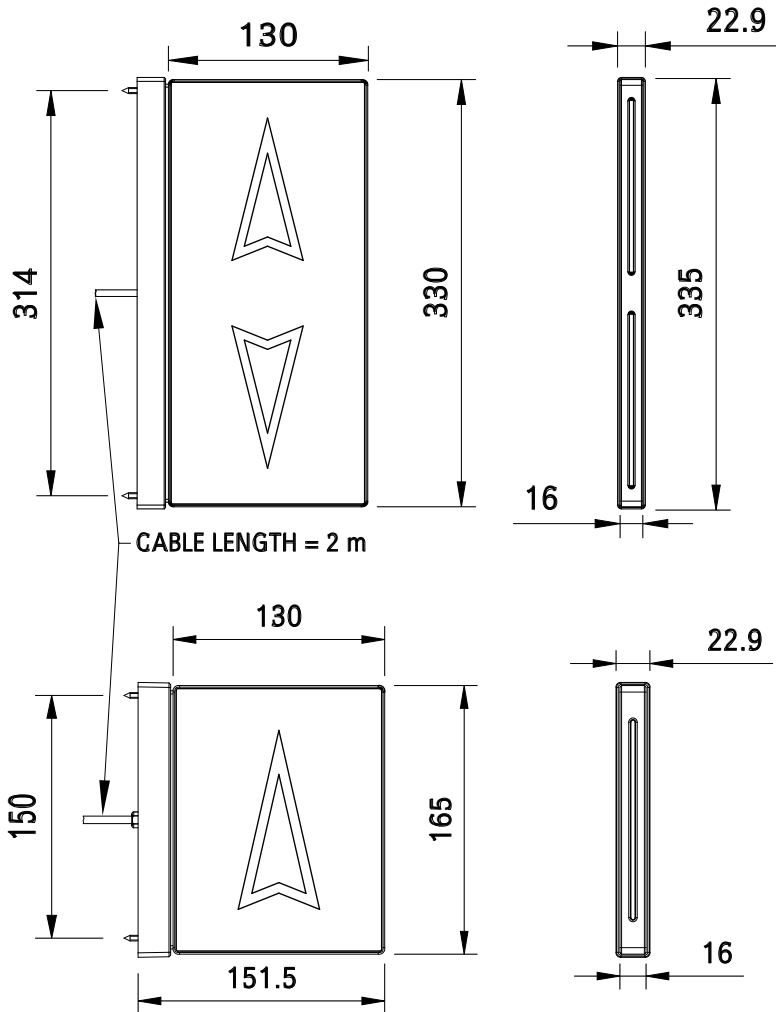
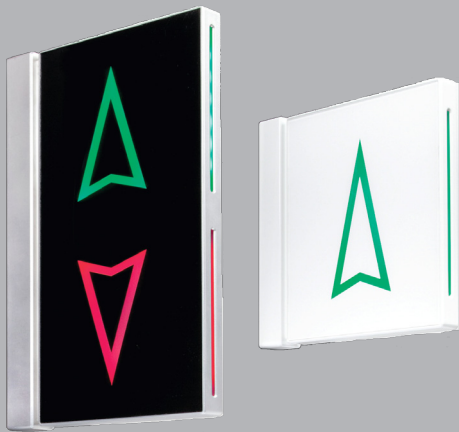

This product is designed to meet the requirements of the following codes and regulations either in its standard form or through variants:

EN81-1/2	✓
BS8300	✓
M2/S2	✓
EN81-70	✓
B44	✓
EN81-71	X
AS1735.12	✓
EN81-72	X
A117.1	✓
EN81-73	X
EN60529	IP42

For more information on our indicator range contact us at:

Dewhurst UK Manufacturing Ltd
Unit 9, Hampton Business Park
Feltham
TW13 6DB
United Kingdom

Tel: +44(0) 20 8744 8200
Fax: +44(0) 20 8744 8299
Email: info@dewhurst.co.uk
www.dewhurst.co.uk

technicals

- Blade side panels made of Acrylic with gloss finish
- Blade frame and base is Zinc alloy with gloss powdercoat finish
- Arrow height 75 mm
- Voltage: 24V d.c.
- Current (typically): 20mA @24V d.c.
- LED illumination (long life: 100,000+ hours)

benefits

- Smart, modern appearance
- DDA compliant
- Long-life LED illumination
- Easy installation, with or with faceplate

options

- Side panel and frame colours available: gloss black and white
- Wide range of illuminated colours including red, green, blue and white
- Optional gong/speaker can be provided at extra cost