



Dewhurst US95-AB Compact 2 Pushbutton with Microban® Antibacterial Protection

The new US95-AB Pushbutton is manufactured with Microban antibacterial protection to help prevent the unwanted growth of harmful bacteria. Bacteria can multiply on lift pushbuttons every 20 minutes. Microban technology makes product surface hostile to microscopic organisms, making them unable to live, grow and reproduce. Whilst providing protection the US95-AB Braille pushbutton also meets all the requirements for the visually impaired. The wide tactile legend can be easily seen from all angles and can be illuminated in a variety of colours. The Braille dots below the legend are Standard English Braille. The pressel background is white polycarbonate providing good contrast with legend and faceplate. The US95-AB is available with the standard Compact 2 or Compact 3 bodies.

Features & Benefits

- Microban® antibacterial protection
- Resistant to many bacteria including MRSA
- 15mm tactile legend with Braille
- A halo of light between the pressel and surround via a patented hidden recess encircles the pressel and illuminates the legend
- Legend & halo can be constantly illuminated at half intensity, switching to full intensity for indication of position or call acceptance
- Large range of pressel legends
- Vandal resistant
- Meets EN81-1/2, EN81-70, EN81-71 (Category 2), EN81-72, EN81-73, EN60529 (IP54)



What is Microban® Protection?

Microban antibacterial protection is built into our US95-AB product to protect against the growth of potentially harmful bacteria that can cause contamination, odours or the build up of moulds and mildew.

Microban protection will not wash out or wear away and is designed to last the lifetime of our product. Microban antibacterial protection neutralises bacterial ability to function, grow and reproduce. Microban protection is evenly distributed throughout the product even in hard to clean areas.

Illumination, Finishes & Marking

- Wide range of colours for illumination including (non), red, yellow, green, blue and white
- Pressel finish is white polycarbonate with Microban® protection
- Surround finish is black polycarbonate with Microban® protection
- Single, dual and bicolour illumination
- A large range of legends in Helvetica Medium characters & symbols are available
- 15mm high, tactile, grey characters/symbols are formed during the moulding of the pressel. Standard English Braille appears below the characters/symbols.



Dimensions

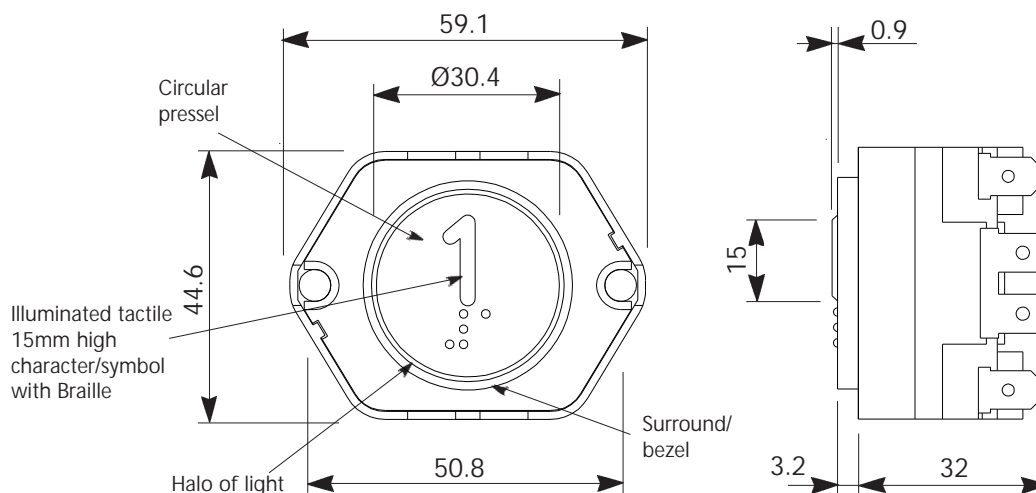

Compact 2 Pushbuttons can be supplied loose or incorporated into stations with 1.5mm or 2.5mm stainless steel faceplates, with a vertical pitch of 50mm and horizontal pitch of 60mm i.e the pushbutton body can be rotated through 90 degrees (horizontal version shown above). If pushbuttons are supplied loose, spacers are provided to accommodate the differing faceplate thickness.

Technical Details

Weight:	70grms		
Moulded in:	High grade polycarbonate with Microban® antibacterial protection		
Pressel plate material:	White polycarbonate with Microban® antibacterial protection		
Surround material:	Black polycarbonate with Microban® antibacterial protection		
Pushbutton size:	51.9mm w x 44.6mm h x 32.0mm d		
Pressel size:	Ø30.4mm x 3.2mm d		
Legend size:	15mm high, Helvetica medium characters		
LED current:	20mA (typically)		
LED voltage:	12/24/30/48/110V a.c./d.c. ±15%		
Operation:	Wiping action, slow make and break with solid silver contacts		
Ratings:	10 amps max		
	240V a.c. at 3.0 amps max. resistive loads	- min. no. of operations:	1 x 10 ⁶
	240V d.c. at 0.5 amps max. resistive loads	- min. no. of operations:	2 x 10 ⁶
	110V d.c. at 100mA max. inductive TC40ms	- min. no. of operations:	1 x 10 ⁶
	12V d.c. at 5mA max. resistive loads	- min. no. of operations:	10 x 10 ⁶
Contact arrangements:	2 N/O, 2 N/C or 1 N/O + 1 N/C	Please note that it is possible for the N/O contact to make before the N/C contact has opened on the 1 N/O + 1 N/C configuration	
Code compliance:	Meets EN81-1/2, EN81-70, EN81-71(Category 2), EN81-72, EN81-73		
IP Rating:	BN60529 (IP54)		

Cutouts & Stud Positions

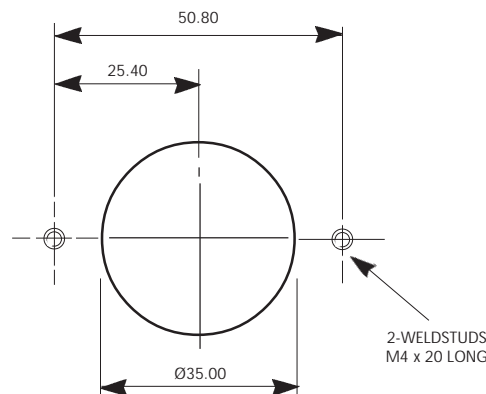

Cleaning your US95-AB Pushbutton

Many **Dewhurst** lift products are made of **polycarbonate** (Using GE's **Lexan®** or Bayer's **Makrolon®**).

The US95-AB is highly durable and vandal resistant but can be damaged by aggressive cleaning agents to plastic parts (pushbutton pressel), Dewhurst therefore recommends:



Clean the part with a cotton cloth and warm water **before** applying the cleaning product



Use **PH-neutral or slightly acid cleaning products only** (including aromatised ones) Ethylic alcohol, isopropyl alcohol or ethylene glycol based multipurpose cleaning products and sigh soaps are suggested.



Dilute the cleaning product in warm water and apply using a wet cotton cloth.



Grease, glue and paint may be removed with ethylic alcohol or isopropyl alcohol.

Recommended Cleaning Products (*):

Europe	North America
Windus - Brial Top - Ecolab Mr. Proper Surfaces Delicates - Proctor & Gamble Palmolive, Colgate Palmolive	Formula 409® Cleaner Degreaser Joy®, Proctor & Gamble Windex, Drackett Products Palmolive, Colgate Palmolive

(*): Due to the vast number of cleaning products available on the market, the list of recommended products above is an illustration only

Note:

- Do not use abrasive cleaning agents
- Do not use sharp tools to remove dirt (chewing gum, glue, etc.)
- Do not use solvents based with Ketones, benzene, methanol, toluene (also known as methylbenzene or phenyl methane) or alkaline and ammonia based cleaning agents
- Do not use cleaning agents at high temperatures
- Do not leave cleaning agents on the parts for long periods: remove immediately after cleaning using a wet cotton cloth and warm water
- Do not use dry cotton cloths and sponges